

**MIDLAND<sup>®</sup>**



# 77-805

## OWNER'S MANUAL

40-Channel mobile citizens band transceiver.  
27 MHz F.M. (MPT 1320) United Kingdom System

# Midland 77-805

40-Channel Mobile/Portable  
CB Transceiver



## Features:

State-of-the-art techniques have been used in the electronics of your new Midland CB.

Including Midland Power performance — with a transmitter rated for legal maximum 4-watt output power with high level modulation.

Plus a highly sensitive, selective dual-conversion superheterodyne receiver with tuned RF stage and built in, automatic noise limiter.

Outside, it's designed to give you the most convenient operation possible.

No other design aspect has been given more attention than the time- and motion-saving features built into your new radio, microphone and mounting system.

You'll find and enjoy the benefits of this attention to detail all across the control panel. For example:

- Large-scale, easy-reading green LED 40-channel indicator.
- Full-range, variable squelch control.
- Fully, electronic signal/power meter.
- Front Mounted plug-in deluxe microphone.
- Precision PLL (Phase Locked Loop) tuner.
- Fresh, attractive styling with satinfinish bezel.
- Mounting bracket for easy installation and removal.
- Rugged all metal cabinet.
- New sub miniature size-fits almost anywhere in any car.

# Contents

Midland 77-805 features _____	Pages 5-6
Installation instructions _____	Page 7
Location selection _____	Page 7
Mechanical mounting _____	Page 7
Power _____	Page 8
Mounting main unit _____	Page 8
Antennas _____	Pages 9-10
Telescopic antenna _____	Page 9
Base station operation _____	Page 9
Mobile Antennas _____	Page 10
Selection (minimum requirements) _____	Page 10
Effect of location of performance _____	Page 10
Installation _____	Page 10
Tuning _____	Page 10
Operating instructions _____	Page 11
Operating controls, connectors	
Functions and uses _____	Pages 12-13
10-Code usage _____	Page 14
Channel frequency chart _____	Page 15
Range _____	Page 15
Noise _____	Page 15
Trouble-shooting aids _____	Page 16
Noise suppression _____	Page 16
Common problems and solutions (chart) _____	Page 17
Technical specifications _____	Page 17
Circuit diagrams _____	Pages 18-20

# Midland 77-805 Mobile/Portable CB Operating Controls

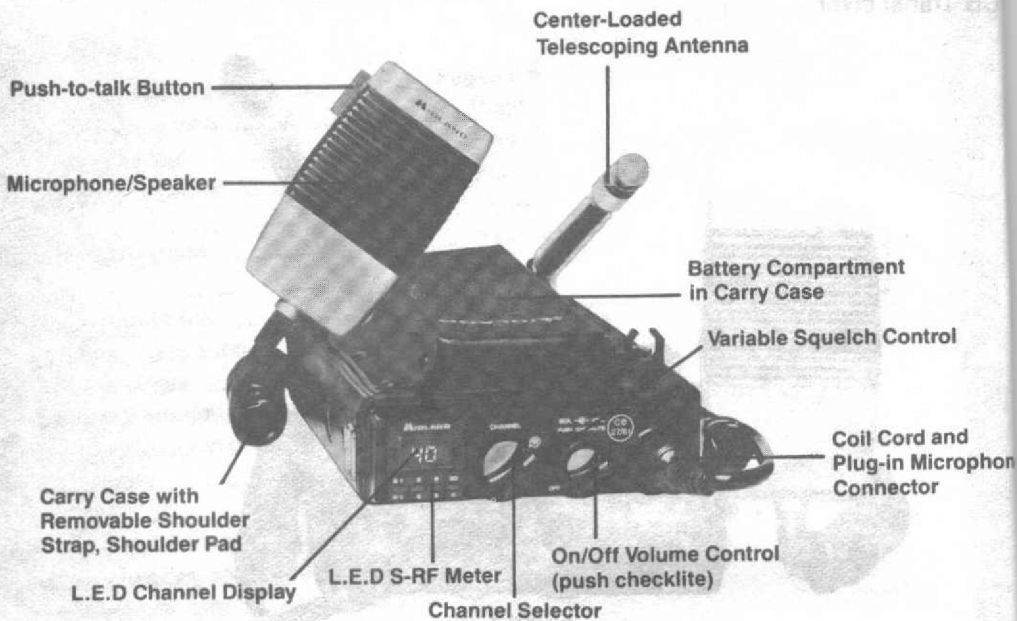

## SO-239 Mobile Antenna Connector

## Coax 12V. DC Power Jack



## Portable Antenna Mount

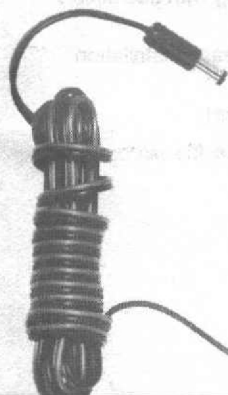

## Cigarette Lighter DC Power Cable



## Universal Mount



# How to Install Your Midland 77-805 Mobile/Portable CB

Mounting Bracket  
Lock Washer x 2  
Tapping Screw x 2  
Rubber Washer x 2  
Bolt x 2

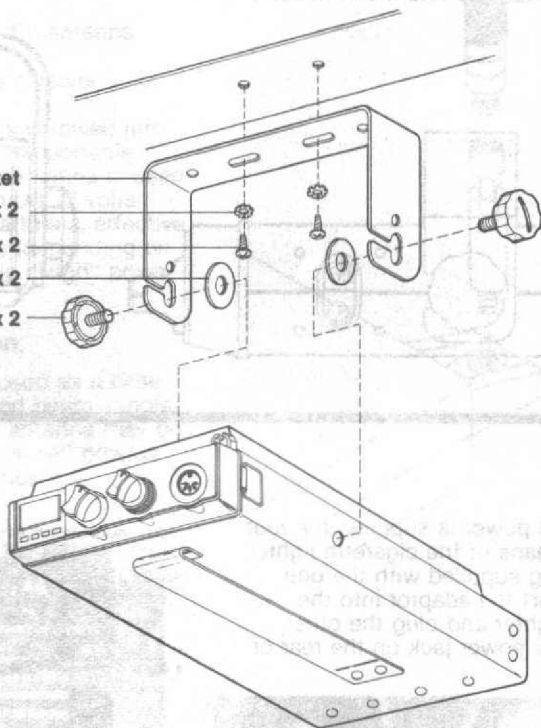

A location in the car or truck should be chosen carefully for convenience of operation and non-interference with normal driving functions. Mounting may be under the dash or instrument panel or any place a secure installation can be made.

## Mechanical mounting.

**Step 1:** Heeding the caution, use the mounting bracket as a template for marking the location of screwholes under your dash. Use an awl, nail or other sharp, pointed object to mark the metal.

**Step 2:** Drill a 1/8" hole for each screwhole in the mounting bracket. Attach the bracket to the dash with the 3/8" Phillips machine screws provided.

*Extreme care should be exercised when drilling into dash to avoid damage to under-dash electronic ignition, cruise control, instrument and/or accessory wiring.*

**Step 3:** Locate and secure the radio into the mounting bracket allowing working space for later power connections. (See next page.)

## Mounting the main unit.

**Step 1:** Position the main unit between the bracket arms in line with the retention knobs. Set the angle for optimum operating comfort and accessibility.

**Step 2:** Tighten the retention knobs.

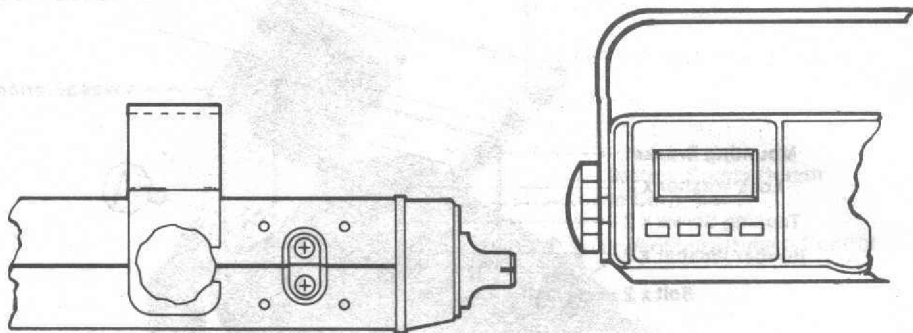

## Power

Electrical power is supplied for your radio by means of the cigarette lighter adaptor plug supplied with the unit. Simply insert the adaptor into the cigarette lighter and plug the other end into the power jack on the rear of the radio.

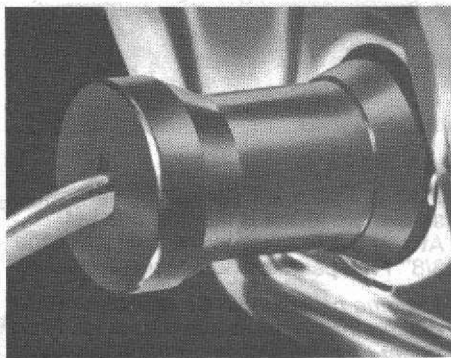

The 77-805 also features a carrying case with a battery holder. 10 pcs of heavy duty 1.5 volt "AA" cells will fit into this portable power source. For portable use, simply plug in the small plug from the battery case into the jack marked 12 volts DC located on the rear of the radio.

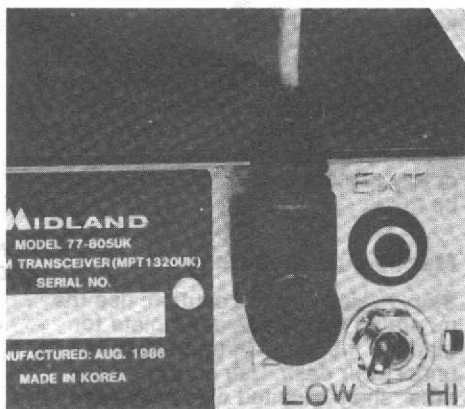

# Midland 77-805 Antenna Installation

## Telescopic antenna for portable operation.

Follow this procedure for antenna installation:

1. Telescopic antenna is screwed into universal mount.
2. The universal mount is screwed into the threaded base of the portable antenna bracket. This antenna is used for portable operation. At 12 volts using fully charged batteries, effective range is up to 3 miles (depending on terrain) with the unit in "High" power position.

## Base station operation.

When the 77-805 is used as a base station, any Citizens Band beam, dipole, ground plane or verticle antenna may be used. A ground plane type will provide greater coverage, and since it is essentially non-directional, it is ideal in base station to base station, or point to point operation, a directional beam will give greater distance even under adverse conditions. The range of the transceiver depends basically on the height of the antenna so whenever possible, select the highest location within 27 MHz FM limits.

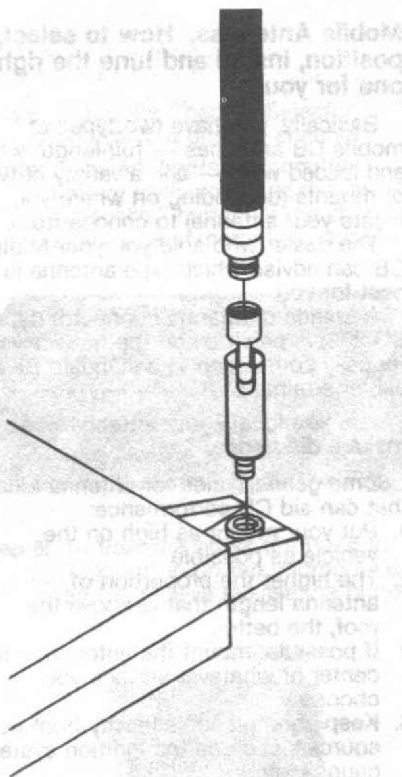

## Mobile Antennas: How to select, position, install and tune the right one for you.

Basically, you have two types of mobile CB antennas — full-length whip and loaded whip — and a variety of types of mounts (depending on where you locate your antenna) to choose from.

The dealer who sold you your Midland CB can advise which type antenna is best for you.

A standard antenna connector (type SO 239) is provided on the transceiver for easy connection to a standard PL 259 cable termination.

### Where you locate your antenna does make a difference.

Some general rules for antenna location that can aid CB performance:

1. Put your mount as high on the vehicle as possible.
2. The higher the proportion of antenna length that is above the roof, the better.
3. If possible, mount the antenna in the center of whatever surface you choose.
4. Keep antenna cables away from noise sources, such as the ignition system, gauges, etc.
5. Make sure you have a solid metal-to-metal ground.
6. Exercise care to prevent cable damage.

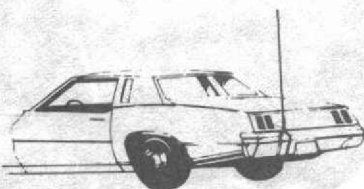

Bumper Mount

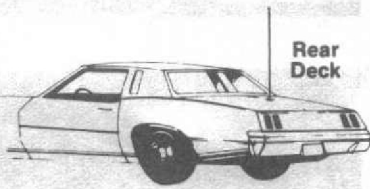

Rear Deck



Gutter Mount



Front Cowl Mount

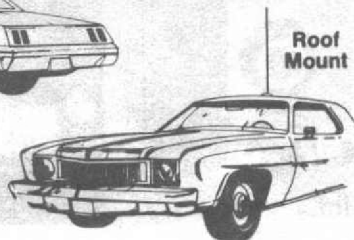

Roof Mount

Midland 77-805  
Antenna Installation

Essentially, you have five location choices: the roof, gutter, rear deck, front cowl or rear bumper.

Where you decide to locate your antenna will determine the type of antenna you install. Again, consult your Midland CB Dealer for advice and guidance and measure your needs against the attributes of the various Midland antenna models he carries.

### Antenna installation.

Follow the manufacturer's installation instructions carefully.

**Warning:** Never operate your CB radio without attaching an antenna or with a broken antenna cable. This can result in damage to transmitter circuitry.

### Tuning your antenna.

Some antennas are factory tuned. However, performance can usually be improved by slightly lengthening or shortening its length, using a Standing Wave Ratio (SWR) meter.

For the exact procedures to be used, refer to the antenna manufacturer's installation manual.

You can buy an SWR meter separately, or have your antenna checked by your Midland CB Dealer's service department.

# Midland 77-805 Operating Instructions.

After you have installed and wired your antenna and you are receiving DC power from the battery pack or the cigarette adaptor plug, you are ready to get into effective, satisfactory operation.

**Step 1:** Insert the MIC plug in the MIC connector.

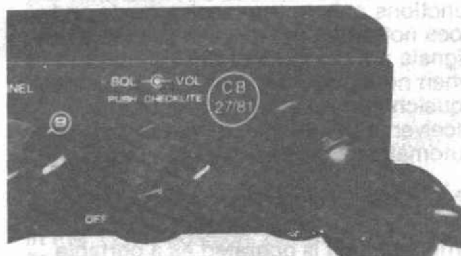

**Step 2:** Make sure your Antenna is securely connected to the antenna connector.

**Step 3:** Turn the power on. For "low" power, place the switch on the back panel to the "low" position.

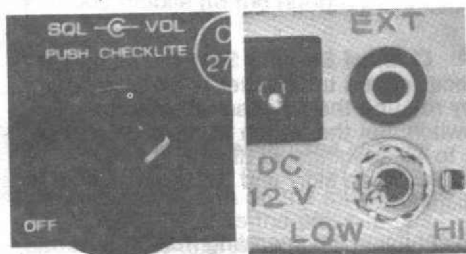

**Step 4:** Temporarily turn and place the SQUELCH control in slight clockwise position.

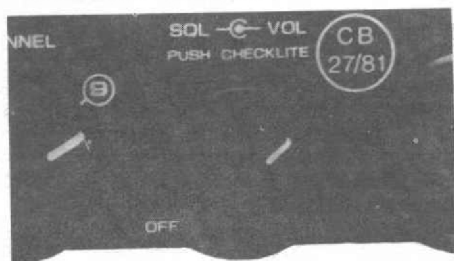

**Step 5:** Place the Channel Selector control to a desired channel.

**Note:** If you are operating from the battery pack, you must depress the "checklite" button for the channel indicator and meter to illuminate.



**Step 6:** To transmit press the Push-to-Talk button on the microphone and to receive release the button.



## Important.

Do not short circuit the antenna or do not try to transmit without an antenna. This may cause damage to the output power transistors. Transmit only after carefully checking antenna connections.

# Operating Controls, Connectors: Their Functions and Uses



**A Volume/On-Off.** The volume control varies the sound output of the speaker/microphone (or optional external speaker). Clockwise rotation increases volume.

**Squelch Control.** Quiets the receiver when signals are not being received and allows a quiet standby operation. It functions only in the receive mode and does not affect the receiver volume when signals are being received. To adjust, when no signals are present, rotate the squelch control clockwise until the receiver is quieted. Incoming signals will automatically release the squelch.

**Check Lite Switch.** The "CHECK LITE" switch is part of the volume control. When the unit is operated as a portable the check-lite switches on for lighting the channel selector and meter. This is designed to save battery consumption. When mobile DC power is used, channel selector and meter should be constantly illuminated.

To operate, simply push the volume control in. To disengage simply press the volume control a second time.



**B Channel Selector Switch.** Tuning the receiver and transmitter is simultaneous by rotating the 40 channel selector switch. Set the switch to desired channel 1 to 40 as indicated directly on the switch knob skirt and L.E.D. channel display.

**Note:** If you are operating from the battery pack the checklite switch must be on for the channel indicator to illuminate.



**C Electronic S/RF Meter.** During reception, relative incoming signal strength will be indicated as the bar segments of the meter illuminate along the "S" meter scale. In the transmit mode of operation, outgoing signal strength in watts is indicated on the Power (P) scale.

**D 12 Volt DC Power Jack.** This jack is for connecting the cigarette lighter adaptor plug or lead from the portable battery pack.

**E External Speaker Jack.** Used for an external speaker (8 or 16 ohms) connection. This jack accepts a standard (3.5 mm) 2 circuit phone plug.

**F High/Low Switch.** This switch controls the power output of your 77-805. In the "HI" position the unit transmits at maximum power. In the "LOW" position, power is reduced. This conserves batteries.

**G Antenna Connectors.** Used for antenna connection, matches PL-259 standard type. There are two antenna connectors — one portable (to the left)/one mobile (to the right).

**H Microphone/Speaker.** The receiver and transmitter are controlled by the press-to-talk button on the microphone. To transmit, depress the press-to-talk button on the microphone. While holding the microphone 3 to 4 inches from your mouth, speak clearly at a normal voice. You can hear the voice at the microphone/speaker.

**Accessories Included:** Texon carry case with removable strap and shoulder pad, battery compartment and connector, belt loop, metal microphone clip, removable universal mount, center coil-loaded telescopic antenna, mobile mounting bracket, Owner's Manual.

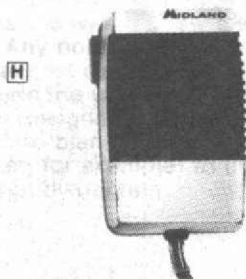
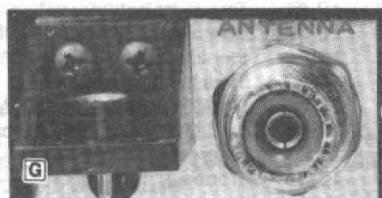
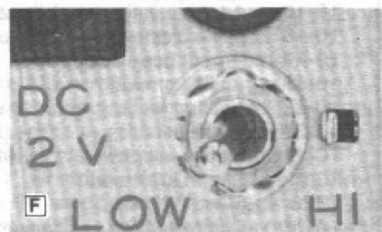
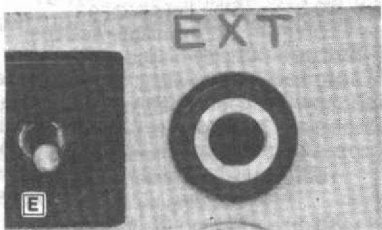
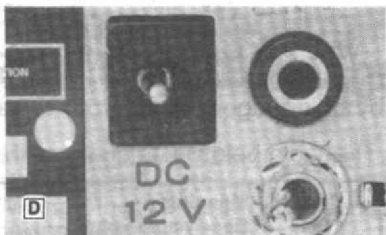

**Why and how to use the "10 Code."** Developed over the years by official agencies in order to save

time and provide precise, clear messages, the "10-Code" has become a popular tool for Cbers.

The table below lists some of the more common codes and their meanings.

Code	Meaning	Code	Meaning
10-1	Receiving poorly	10-35	Confidential information.
10-2	Receiving well.	10-36	Correct time is.
10-3	Stop transmitting.	10-37	Wrecker needed at.
10-4	OK, message received.	10-38	Ambulance needed at.
10-5	Relay message.	10-39	Your message delivered.
10-6	Busy, stand by.	10-41	Please turn to Channel.
10-7	Out of service; leaving the air.	10-42	Traffic accident at.
10-8	In service, subject to call.	10-43	Traffic tie-up at.
10-9	Repeat message.	10-44	I have a message for you.
10-10	Transmission completed, standing by.	10-45	All units within range report.
10-11	Talking too fast.	10-50	Break channel.
10-12	Visitors present	10-60	What is next message number?
10-13	Advise weather/road conditions.	10-62	Unable to copy; use phone.
10-16	Make pickup at.	10-63	Network directed to.
10-17	Urgent business.	10-64	Network clear.
10-18	Anything for us?	10-65	Awaiting your next message/assignment.
10-19	Nothing for you; return to base.	10-67	All units comply.
10-20	My location is.	10-70	Fire at.
10-21	Call by telephone.	10-71	Proceed with transmission in sequence.
10-22	Report in person to.	10-77	Negative contact.
1023	Stand by.	10-81	Reserve hotel room at.
10-24	Completed last assignment.	10-82	Reserve room for.
10-25	Can you contact?	10-84	My telephone number is.
10-26	Disregard last information.	10-85	My address is.
10-27	I am moving to Channel.	10-91	Talk closer to mike.
10-28	Identify your station.	10-93	Check my frequency on this channel.
10-29	Time is up for contact.	10-94	Please give me a long count.
10-30	Does not conform to FCC rules.	10-99	Mission completed; all units secure.
10-32	I will give you a radio check.	10-200	Police needed at.
10-33	Emergency traffic.		
10-34	Trouble at this station.		

## Frequency-channel number chart.

Frequency	Channel
27.60125	1
27.61125	2
27.62125	3
27.63125	4
27.64125	5
27.65125	6
27.66125	7
27.67125	8
27.68125	9
27.69125	10
27.70125	11
27.71125	12
27.72125	13
27.73125	14
27.74125	15
27.75125	16
27.76125	17
27.77125	18
27.78125	19
27.79125	20
27.80125	21
27.81125	22
27.82125	23
27.83125	24
27.84125	25
27.85125	26
27.86125	27
27.87125	28
27.88125	29
27.89125	30
27.90125	31
27.91125	32
27.92125	33
27.93125	34
27.94125	35
27.95125	36
27.96125	37
27.97125	38
27.98125	39
27.99125	40

## Factors Affecting Effective CB Range.

Essentially, they're the same influences that optimize or limit AM, FM and other kinds of performance in moving vehicles:

**Terrain:** Hills and valleys naturally interrupt and shorten CB signals.

**Weather.** You can expect that CB range will be reduced — perhaps drastically — in times of atmospheric disturbance, such as in a thunderstorm or heavy snow. Sunspots, too, are known to adversely affect CB performance.

**Obstructions.** Inside a tunnel, covered parking garage or viaduct, CB sending/receiving capability may be cut off altogether.

In short, you can expect to maintain maximum transmitting/receiving performance in flat, open country in stable (not necessarily clear) weather conditions.

Should effective range be limited in these conditions, check to see that your CB is connected properly and your antenna adjusted correctly. It may be necessary to consult your Midland CB Dealer's service department.

### What causes noise?

If you have an abnormal noise problem, the chances are your vehicle itself is the cause.

A CB receiver is a very sensitive instrument, able to pick up small noise signals and amplify them — particularly if the source of these signals is within a few feet of your CB.

Any noise that comes from your CB almost certainly comes from outside the unit itself. Devices have been designed into your Midland CB (a noise blanker or an automatic noise limiter, for example) to minimize this kind of distraction.

# Trouble-Shooting Aids.

Frequently, there are simple, quick actions you can take to eliminate or minimize such problems as interference and noise.

## Noise suppression.

A very common source of excessive noise is the ignition system of a CB owner's vehicle. If you suspect this is true, simply turn off the ignition and set the key in the accessories (ACC) position.

This way you'll provide power to the transceiver, minus any ignition interference that might exist. If the noise goes away, you know instantly that the ignition system is the culprit.

Still, there are a number of places in the ignition system where noise can originate.

**Sparkplugs** and sparkplug wires are probably the worst noise producers. To eliminate this kind of noise, you can take any of four simple measures: (1) Install resistive sparkplug suppressors, (2) resistor sparkplugs or (3) resistance-wire cabling, between plugs and the distributor and also between the distributor and ignition coil. (4) Replace old plugs and sparkplug wiring and properly tune the engine. This generally cures most noise.

Many cars come suppressor-cable equipped. If yours didn't (consult your vehicle owners manual or dealer service department to be sure), you can get it at any auto supply store and, given a moderate amount of mechanical skill, install it yourself.

**Caution: Do not undertake any ignition-system repairs or modifications without either professional help or some automotive service experience.**

**Generator-brush sparking** can create an annoying "whine." It's caused by a dirty commutator, and is eliminated by polishing its surface with fine-grade emery cloth, and cleaning grooves with a small, sharp tool.

**Voltage regulators** can cause a "hashy" sound in your CB when relay contacts jitter open and closed when the battery is fully charged. To eliminate this noise, mount coaxial feedthrough capacitors at the battery and armature terminals on the regulator box.

**Alternator** slip rings should also be kept clean and good brush contact maintained to minimize CB noise.

In addition, single-contact alternator regulator boxes need a coaxial capacitor at the ignition terminal. Double-contact units should have a second capacitor at the battery terminal. Shielding between the regulator and alternator may be needed as well. Be sure to ground the shield at both ends.

Infrequent, though real, noise generators like your car's heat fan, turn signals, electric-windows and windshield-wiper motors can also be silenced with a coaxial capacitor (consult your serviceman).

**Wheels and tires** can also cause CB noise also. Wheel noise is eliminated by putting static-collector springs between the wheel spindle bolt and grease retainer cup. Tire static can be quieted with antistatic powder applied inside each wheel.

**Antenna corona-discharge noise** — most frequently occurring with sharp-pointed "whip" models — can happen just before or during electrical storms. The only cure is for the storm to blow over or pass.

# Quick-Check Chart for CB Problems.

## SOLUTIONS:

### COMMON CB PROBLEMS:

	Check power connection.	Check 2-amp fuse.	Check squelch adjustment.	Check on/off switch.	Change to active channel.	Check antenna connection.	Fully depress connection and cable.	Check microphone connection.	Check "Check-lite" Switch	Check Batteries
No sound or channel light.	●	●		●					●	●
Channel light but no sound.			●			●	●			
Poor reception.					●		●			●
Transmission problems.					●	●	●			●
Unclear reception.					●					●
No voice reception.			●	●						●

**Caution:** The 2-amp fuse included with this unit is an important safety feature which must not be circumvented. Removal of this fuse or the use of a fuse greater than 2 amps may result in overheating and/or fire and consequential damage to the unit or vehicle. If a replacement 2-amp fuse burns out, have the unit inspected and repaired by a qualified service technician.

## Midland 77-805 Technical Specifications.

### General Construction.

- Unit size: 1 1/4"(H) x 4 1/2"(W) x 6 11/16"(D)
- Overall size: (in case) 2 3/4"(H) x 4 23/32"(W) x 8 17/64"(D)
- Unit weight: 2 1/10 lbs.
- Channels: 40, all supplied.
- Circuitry: P.L.L.
- Power sources: 13.8 volts DC (mobile), negative ground, 12 volts DC (portable).
- Receiving system: Dual conversion superheterodyne with tune RD.

### Electrical Specifications.

All test conditions and methods are in accordance with EIA standards RS-382 and RS-424 or applicable government regulations.

**Frequency control:** P.L.L.

**Receiver Sensitivity:** 0.7 uV for 12dB SND.

**Receiver Selectivity:** More than 45dB ± 10KHz

**Audio Output:** 4.0 watts (EXT. SP at 8 ohms).

**Intermediate Frequencies:** 1st 1F: 10.695 MHz  
2nd 1F: 455 kHz

**Transmitter Modulation:** High level.

**RF Output Power:** Mobile: 4 watts  
Portable: hi-3 watts  
lo-0.3 watts

### DC Current Drain (Check lite on):

No. Signal	Normal	Limit
Mobile:	250mA	300mA
Portable:	190mA	250mA
10% THD max.	..	
Mobile:	850mA	1000mA
Portable:	600mA	700mA

**Frequency Tolerance:** ± 0.005%.

**Controls:** On/off/volume, variable squelch, channel selector, hi/lo power switch, push-to-talk (on speaker/mike), "Check Lite" switch.

**Jacks and Connections:** Mobile antenna, mobile and external power (coaxial), external speaker, universal portable antenna.

**Accessories Included:** Texon carry case with removable strap and shoulder pad, battery compartment and connector, belt loop, metal microphone clip, removable universal mount, center coil loaded telescopic antenna, mobile mounting bracket, Owner's Manual.

# Parts Layout. Main PC Board.

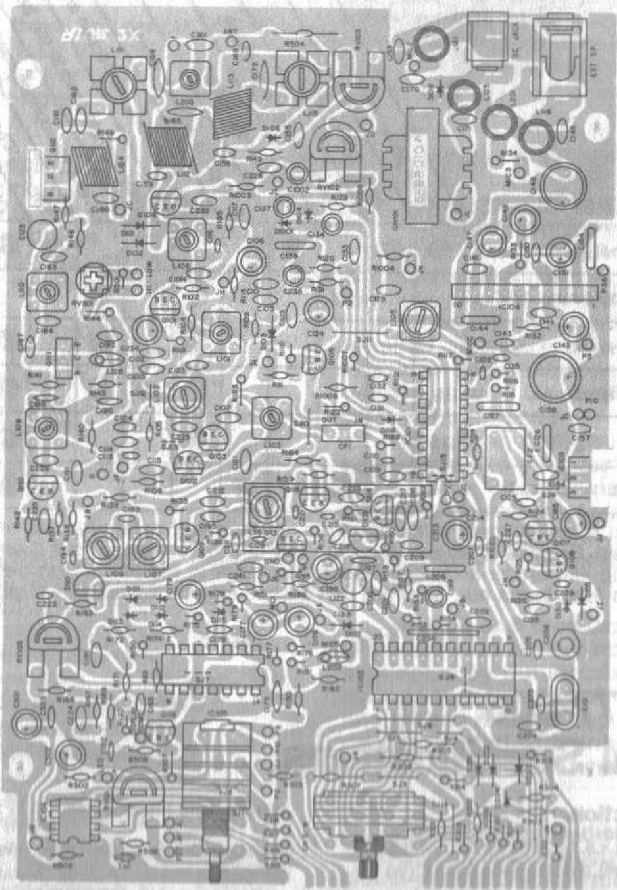

Component side.

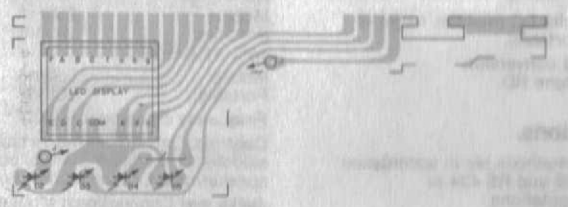

# Parts Layout. Main PC Board. 19510 dimensions

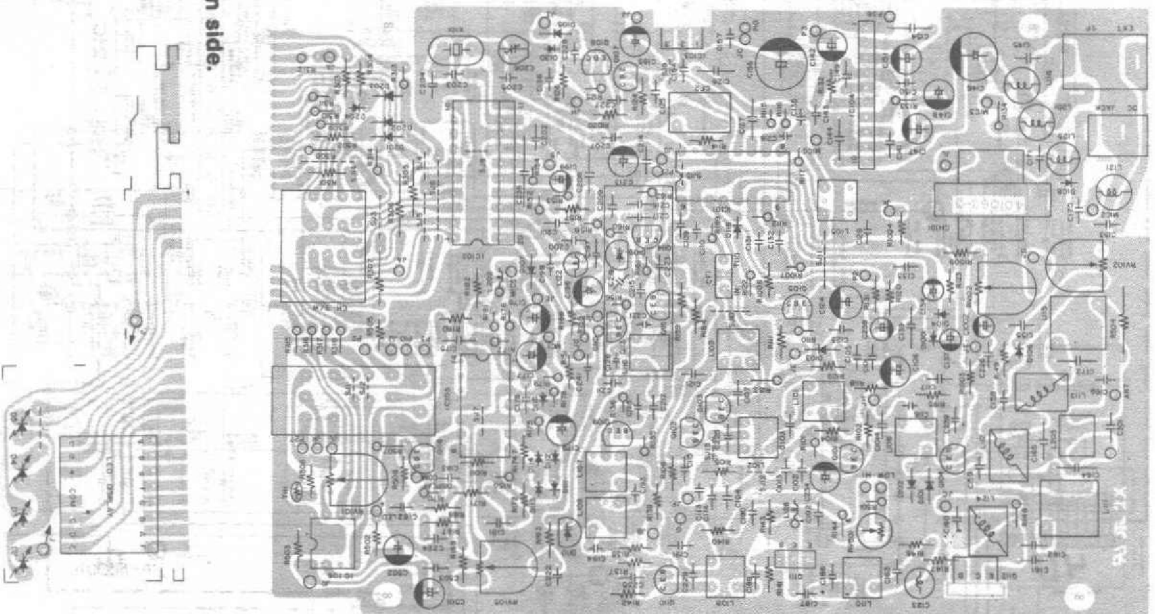

Pattern side.



 **MIDLAND**<sup>®</sup>  
INTERNATIONAL CORPORATION

Printed in Thailand  
Part No. 935281

## **Midland 77-805**

**40-channel mobile citizens band transceiver.**

For your protection, the spaces below are provided for you to record the CB Radio Licence Number and Serial Number of this product. The latter is located on the identification plate attached to the rear cabinet panel. After recording these numbers, keep this record for future reference.

CB Licence No.: \_\_\_\_\_

Serial No.: \_\_\_\_\_

## **Welcome to the world of Midland electronics.**

Congratulations. You've just graduated to the state of the art in mobile CB power, clarity and operating convenience.

In the years ahead, you can expect to realize — time and time again — the real reasons and meaning of the front running position Midland holds among CB users everywhere.

And you'll come to know that Midland Power is more than just a slogan, but the heading of a long list of hearable, seeable benefits.

Like controls designed and located for maximum convenience and ease of operation.

And like the assurance that comes from knowing the nationwide Midland service

network goes with you everywhere you take and use your Midland CB.

As your Midland CB experience unfolds and grows, we hope you'll remember that CB is only one kind of electronic excellence available under the Midland nameplate.

Remember that the same dependability, range and clarity engineered into your CB are also built into a long, versatile line of Midland car stereo receivers, telephones and other electronic Products.