

INTEK FM-800

**AM/FM
80 Channel
Digital
Readout!**

**SOLID STATE AM/FM 80 CHANNEL
CITIZENS BAND 2-WAY RADIO**



Instruction Manual

SPECIFICATIONS

TRANSMITTER SECTION

POWER OUTPUT	4Watt Max (AT 13.8V DC)
EMISSION	6A3
SPURIOUS RESPONSE REJECTION	All harmonic and spurious suppression greater than F.C.C. and D.O.C requirements
MODULATION	AM, 90% typical FM, Deviation 2KHz MAX Max

RECEIVER SECTION

CIRCUIT TYPE	Dual conversion superheterodyne with RF stage and 455 KHz ceramic filter
FREQUENCY	2 crystal-controlled PLL, 80channels in the 27 MHz Citizens Band
SENSITIVITY	1.0 μ V for 10dB S/N
SQUELCH RANGE	0-1mV
SELECTIVITY	70 dB down at \pm 10KHz
IF FREQUENCY	1st IF: 10.695MHz 2nd IF: 455 KHz
IMAGE REJECTION	55dB
AUDIO OUTPUT	3.5W maximum at 8 ohm load
CURRENT DRAIN	250mA on standby (no signal)
CURRENT DRAIN (MAXIMUM)	Less than 1.5A
ANTENNA	Nominal 50 ohms impedance
POWER SOURCE	Operates from nominal 12.6 volts DC, negative or positive ground system
DIMENSIONS (OVERALL)	8.59(W) x 10.32(D) x 3.27(H) inches
WEIGHT	4.4 lbs.

WE RESERVES THE RIGHT TO MAKE DESIGN CHANGES OR MODIFICATIONS WITHOUT INCURRING ANY OBLIGATION TO INCORPORATE THEM IN PRODUCTS PREVIOUSLY SOLD.

INSTRUCTIONS APPLICABLE TO TRANSCEIVERS CARRYING SERIAL NUMBER 00000001 OR HIGHER.

DESCRIPTION

This model is an all-transistor 2-way radio transceiver for mobile operation. A frequency synthesizer circuit provides 80 crystal controlled PLL transmit and receive channels in the 27 MHz Band, engineered for trouble-free performance. Your transceiver uses heat resistant transistors in all critical areas. Current drain on 12 volts DC is exceptionally low. Operation over long periods is feasible even with your engine turned off. The transceiver may also be operated from A.C when used with an optional Power Supply.

RECEIVER

The receiver is a sensitive and highly selective dual-conversion superheterodyne type providing crystal-controlled PLL operation on all 80 CB channels. The circuit incorporates a number of features designed to provide optimum reception. The receiver incorporates an effective full time switchable Automatic Noise Limiter in the audio stages. A ceramic filter provides sharp selectivity and high adjacent channel rejection. As a result, transmissions on adjacent channels cause minimum interference.

A variable squelch control is incorporated to "silence" the receiver when no signals are being received. The squelch circuit is adjustable providing varying degrees of sensitivity to incoming signals.

TRANSMITTER

The transmitter offers crystal-controlled operation on all 80 CB channels, 5 watt DC power input to the final RF with average modulation capabilities is possible by the use of high-efficiency Transistors and low loss components, wiring, and mounting boards. The legal limit of power for this service is provided.

POWER SUPPLY

The transceiver is ready for connection to a 12 volt DC, negative or positive ground system. DC power is provided to the transceiver by means of a fused power lead.

OPERATING CONTROLS AND FEATURES



FIGURE 1

- (1) L.E.D. DISPLAY L.E.D. (Light Emitting Diode) lamp Indicates the channel selected by 80 position rotary-switch.
- (2) S/P-RF ILLUMINATED METER ... Indicates relative incoming signal strength (top scale) and relative RF power output (bottom scale) when transmitting.
- (3) AM/FM SELECTOR SWITCH Selects AM or FM mode of transmission and reception.

- (4) TX INDICATOR LIGHT Lights up when you are transmitting.
- (5) MICROPHONE INPUT 5 Pin socket for push-to-talk microphone.
- (6) ON-OFF/VOLUME Controls output from the built-in speaker, or external speaker connected to the "EXT SP" or PA jack (rear of transceiver). Incorporates "ON-OFF" power switch at the extreme counter-clockwise position.
- (7) SQUELCH, PA CONTROL Used to quiet the receiver during absence of receive signals. Sensitivity to incoming signals is fully adjustable. In corporates PA switch at the extreme counter clockwise position.
- (8) CH, HI-LO SWITCH To tune in channel 41-80, Set Hi-Lo switch to "Hi" position. To tune in channel 1-40, Set Hi-Lo switch to "Lo" position.

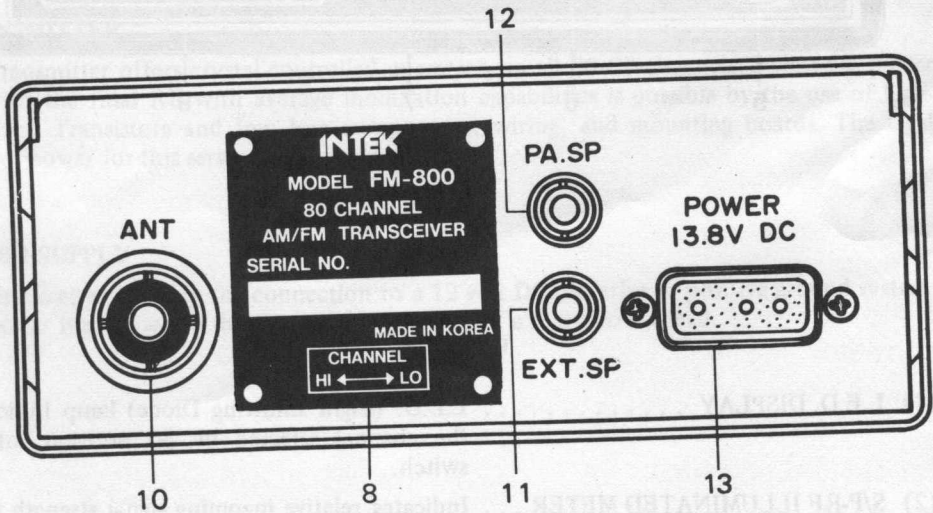

FIGURE 2

- (9) CHANNEL SWITCH This rotary switch selects one of 80 channels for transmit and receive operation.
- (10) ANTENNA CONNECTION To match antenna lead-in cable [RG-58/U or RG-8U] with PL-259 type coaxial connector.
- (11) EXTERNAL SPEAKER JACK Impedance of any device such as headphone connected to this jack should be 8-16 ohms. Insertion of plug into jack automatically silences the transceiver internal speaker.
- (12) PA SPEAKER JACK For Public Address [PA] operation. Horn impedance should be in 8-16 ohm range.
- (13) DC POWER SOCKET 12 volts DC for transceiver supplied through DC power Cable to this socket.

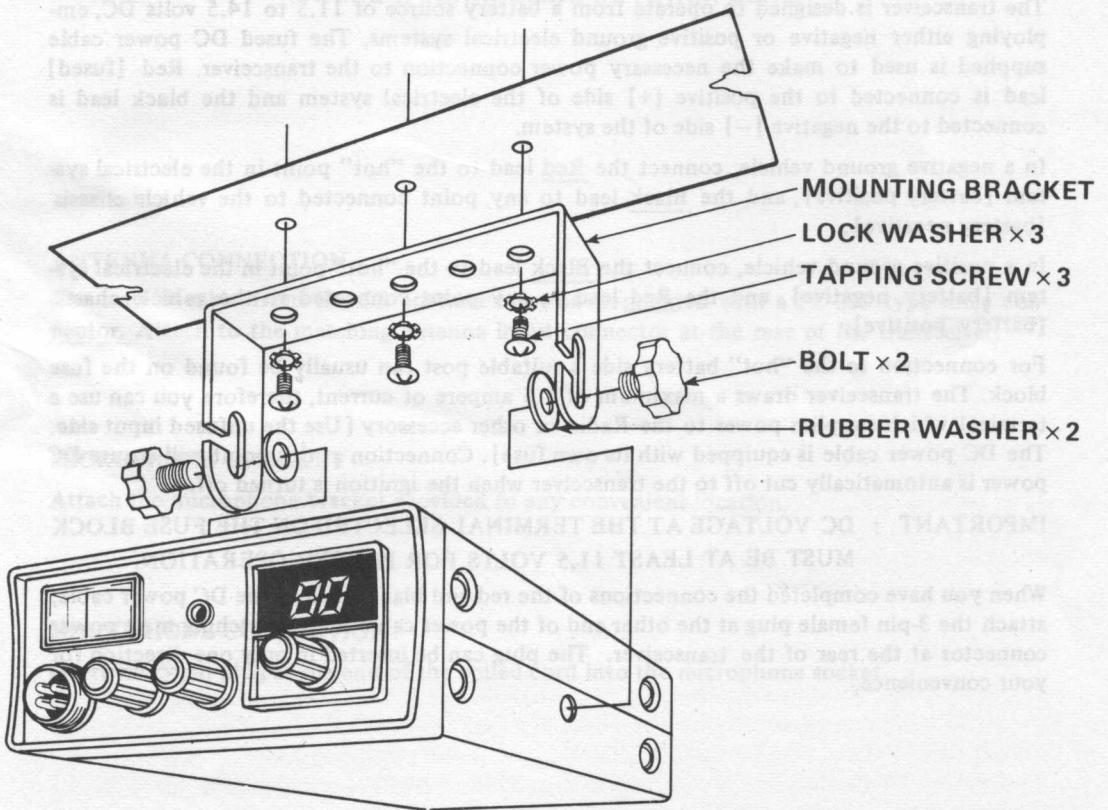

FIGURE 3. MOBILE MOUNTING

TRANSCEIVER INSTALLATION

MOUNTING

Always mount where controls are readily accessible, Unit may be mounted to the underside of the dashboard of a car, truck, etc., utilizing special bracket included with transceiver [see Figure 3]. Attach bracket to the underside of dashboard using the self-tapping screws supplied. Attach the transceiver to the bracket using the two knurled securing screws at the side.

Tilt the unit to the most convenient angle before tightening securing screws.

DC POWER CONNECTIONS

The transceiver is designed to operate from a battery source of 11.5 to 14.5 volts DC, employing either negative or positive ground electrical systems. The fused DC power cable supplied is used to make the necessary power connection to the transceiver. Red [fused] lead is connected to the positive [+] side of the electrical system and the black lead is connected to the negative [-] side of the system.

In a negative ground vehicle, connect the Red lead to the "hot" point in the electrical system [battery positive], and the Black lead to any point connected to the vehicle chassis [battery negative].

In a positive ground vehicle, connect the Black lead to the "hot" point in the electrical system [battery negative], and the Red lead to any point connected to the vehicle chassis [battery positive].

For connection to the "hot" battery side a suitable post can usually be found on the fuse block. The transceiver draws a maximum of 1.5 ampere of current, therefore you can use a terminal which supplies power to the Radio or other accessory [Use the unfused input side. The DC power cable is equipped with its own fuse]. Connection at this point will ensure DC power is automatically cut off to the transceiver when the ignition is turned off.

IMPORTANT : DC VOLTAGE AT THE TERMINAL SELECTED ON THE FUSE BLOCK MUST BE AT LEAST 11.5 VOLTS FOR PROPER OPERATION.

When you have completed the connections of the red and black leads of the DC power cable, attach the 3-pin female plug at the other end of the power cable to the matching male power connector at the rear of the transceiver. The plug can be inserted in only one direction for your convenience.

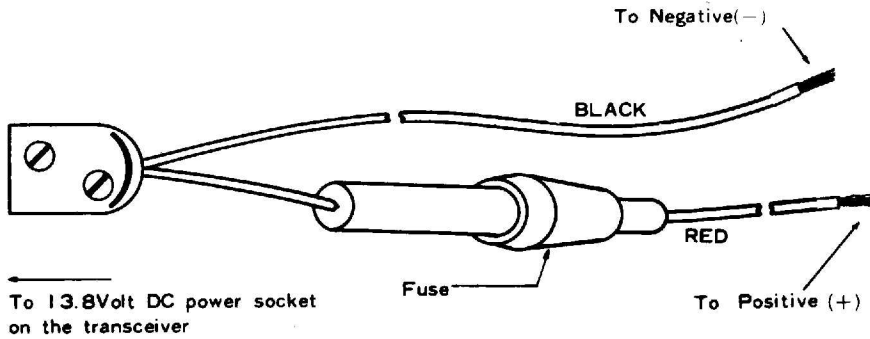

FIGURE 4. CONNECTING DC POWER CORD

ANTENNA CONNECTION

The lead-in cable from the CB antenna must be terminated with a PL-259 type male connector. Attach to the matching antenna input connector at the rear of the transceiver.

MICROPHONE BRACKET

Attach the microphone bracket provided to any convenient location.

MIRCOPHONE CONNECTION

Insert the 5-pin plug at the end of the coiled cord into the microphone socket.

DO NOT TRANSMIT WITHOUT AN ANTENNA CONNECTED TO THE TRANSCEIVER.

ANTENNAS

Efficient mobile operation requires the best possible radio frequency radiator or antenna. Many types are available including trunk mount, bumper mount, roof top mirror, etc. Selection is a matter of available space and personal preference. Virtually unlimited selection is available and you should consult your dealer for his specific recommendation. All good antennas are packaged complete with hardware and connecting cable. Usually no tools are required, although some mounting methods require a small hole be drilled. Remember if you have a choice generally speaking a longer antenna performs best and the higher the better.

IGNITION INTERFERENCE

Normally the suppression on modern automotive engines is adequate to prevent annoying interference to your CB transceiver. If it does not, consult your dealer who will recommend additional suppression measurements.

RECEIVING

1. Set AM/FM selector switch to the broadcast band you want.
2. Select desired channel using the channel Selector Switch.
3. Rotate "squench" control to the extreme counter-clockwise position.
4. Rotate the "VOLUME/ON-OFF" switch clockwise, to apply power. Operation will be instantaneous.
5. Set the "VOLUME/ON-OFF" switch clockwise to a comfortable listening level [approximately 1/3 setting]. The receiver is now ready to operate.

SQUELCH ADJUSTMENT

The Squelch control eliminate annoying background noise in the absence of signals. To adjust the SQUELCH control properly turn up VOLUME until background noise is heard Rotate the SQUELCH slowly clockwise until the background noise just disappears. At this point the receiver will be quiet under "no-signal" conditions, however a reasonable strength incoming signal will overcome the squelch action and be heard. As the control is advanced the squelch action is progressively increased and stronger incoming signals are needed to overcome it. To receive weak signals or to disable the squelch circuit turn the control fully counter clockwise.

EXTERNAL SPEAKER JACK

Recommended plug for the EXT SPEAKER jack is a "TINIPLUG" subminiature phone plug. The impedance of earphones or speakers connected should be 8-16 ohms. Insertion of a plug automatically silences the transceivers internal speaker.

SIGNAL STRENGTH METER

When receiving, this meter provides a relative indication of signal strength in "S" units providing a means of comparison between one received signal and another.

TRANSMITTING

Prior to operating your transmitter do the following.

1. Your Class D citizens band equipment license must be posted at the main control station location.
2. A properly executed mobile identification card, 452C, must be affixed to the mobile unit.
3. Rules Part 95 must be read and understood.

To transmit, depress the push-to-talk button on the microphone. The Red Transmit Indicator light will come on and will "flicker" slightly as you speak into the microphone. Use the microphone like a telephone speaking several inches from the face. Do not shout, use a normal speaking voice.

When you are transmitting, the receiver is silenced and reception is, therefore, impossible. In the same way, your signal cannot be heard by another station when he is transmitting - - - each must take turns. To receive again, simply release the microphone push-to-talk button.

INDICATING METER

In transmit position the METER gives a relative indication of antenna RF power output on the bottom power scale. As you speak, the pointer should "flicker" slightly, indicating you are modulating the RF carrier. The RF power meter will read true antenna power output when the transceiver is connected to a 50-OHM resistive load. The level indicator indication will not be accurate if the load is mismatched but this will not adversely affect operation if a standard good quality antenna is used.

USE AS PUBLIC ADDRESS SYSTEM

Provision has been made for Public Address [PA] operation utilizing the microphone and audio stages in the transceiver. For PA operation, use an external high-efficiency public address horn type speaker with an impedance range of 8 to 16 ohms. Connect to the PA jack on the rear panel of the transceiver. The required plug is a subminiature phone plug, a plug is packaged in the accessory package accompanying this unit. PA volume is controlled by the receiver volume control. To switch to PA position, the squelch control must be rotated to extreme counter clockwise position until it clicks to a stop.

AVAILABLE CITIZEN BAND FREQUENCIES

CRYSTAL O.S.C: 10.240MHz

V.C.O FREQUENCIES AND MIXING

CH	CHANNEL	V.C.O		CH	CHANNEL	V.C.O	
	FREQ. (MHz)	TX (MHz)	RX (MHz)		FREQ. (MHz)	TX (MHz)	RX (MHz)
1	26.965	16.725	16.27	41	27.415	17.175	16.72
2	26.975	16.735	16.28	42	27.425	17.185	16.73
3	26.985	16.745	16.29	43	27.435	17.195	16.74
4	27.005	16.765	16.31	44	27.455	17.215	16.76
5	27.015	16.775	16.32	45	27.465	17.225	16.77
6	27.025	16.785	16.33	46	27.475	17.235	16.78
7	27.035	16.795	16.34	47	27.485	17.245	16.79
8	27.055	16.815	16.36	48	27.505	17.265	16.81
9	27.065	16.825	16.37	49	27.515	17.275	16.82
10	27.075	16.835	16.38	50	27.525	17.285	16.83
11	27.085	16.845	16.39	51	27.535	17.295	16.84
12	27.105	16.865	16.41	52	27.555	17.315	16.86
13	27.115	16.875	16.42	53	27.565	17.325	16.87
14	27.125	16.885	16.43	54	27.575	17.335	16.88
15	27.135	16.895	16.44	55	27.585	17.345	16.89
16	27.155	16.915	16.46	56	27.605	17.365	16.91
17	27.165	16.925	16.47	57	27.615	17.375	16.92
18	27.175	16.935	16.48	58	27.625	17.385	16.93
19	27.185	16.945	16.49	59	27.635	17.395	16.94
20	27.205	16.965	16.51	60	27.655	17.415	16.96
21	27.215	16.975	16.52	61	27.665	17.425	16.97
22	27.225	16.985	16.53	62	27.675	17.435	16.98
23	27.255	17.015	16.56	63	27.705	17.465	17.01
24	27.235	16.995	16.54	64	27.685	17.445	16.99
25	27.245	17.005	16.55	65	27.695	17.455	17.00
26	27.265	17.025	16.57	66	27.715	17.475	17.02
27	27.275	17.035	16.58	67	27.725	17.485	17.03
28	27.285	17.045	16.59	68	27.735	17.495	17.04
29	27.295	17.055	16.60	69	27.745	17.505	17.05
30	27.305	17.065	16.61	70	27.755	17.515	17.06
31	27.315	17.075	16.62	71	27.765	17.525	17.07
32	27.325	17.085	16.63	72	27.775	17.535	17.08
33	27.335	17.095	16.64	73	27.785	17.545	17.09
34	27.345	17.105	16.65	74	27.795	17.555	17.10
35	27.355	17.115	16.66	75	27.805	17.565	17.11
36	27.365	17.125	16.67	76	27.815	17.575	17.12
37	27.375	17.135	16.68	77	27.825	17.585	17.13
38	27.385	17.145	16.69	78	27.835	17.595	17.14
39	27.395	17.155	16.70	79	27.845	17.605	17.15
40	27.405	17.165	16.71	80	27.855	17.615	17.16

TRANSCEIVER SERVICING

Transceiver has been fully tested prior to shipment and will not normally require further adjustments.

CRYSTAL CONTROLLED "PHASE LOCKED LOOP" SYNTHESIZING SYSTEM

This transceiver uses a frequency synthesizing system which employs two crystals and the PLL (phase locked loop) circuit to produce 80 transmitting and 80 receiving channels. The accompanying chart shows the operating mode.

INSTRUCTIONS FOR ALIGNMENT

PROTECTIVE COVER

Turn Transceiver over (speaker grille upward), and remove the facing chassis cover (2 screws each side). The speaker is connected by two leads to the main chassis so remove cover with care.

P.L.L CIRCUIT ALIGNMENT

10.24 MHz

Connect a frequency counter to the pin 12 and check to see 10,24000 MHz \pm 100Hz.

VCO ALIGNMENT

1. Set the Radio to channel 80 and in transmit mode. (make certain 50 ohm dummy load or wattmeter is connected to antenna terminal)
2. Connect a circuit tester between T.P.I and ground.
3. Adjust L203 to obtain +5.5V DC.
4. Set the Radio to channel 1 and in receive mode.
5. Check to see the T.P.I DC voltage dropping to a level between 0.3 to 2.8 volt DC.

As long as the DC level stays between 5.5V DC for Transmit at channel 80 and 0.3 to 2.8V DC for receive at channel, the VCO is set properly.

The magnitude of the T.P.I voltage swing is determined by C211 at factory. The optimum value of C211 was found to be around 100 pfd.

ALIGNMENT OF TRANSMITTER CIRCUITRY

RF DRIVER STAGE ALIGNMENT

1. Select channel 19.
2. Connect an oscilloscope to the base of Q301.
3. Adjust L204, L301, L302 for maximum amplitude of scope display (27.185 MHz)
4. Connect the scope to Q302 collector.
5. Adjust L303 for maximum amplitude on scope display.

RF POWER AMPLIFIER ALIGNMENT

1. Set power supply voltage to 13.8V and set the Radio to channel 19 position.
2. Connect a watt meter to the antenna connector.
3. Adjust L304, L305, and L306 for maximum power indication. Also again touch up L303, L302 and 301 to peak power.
4. When all coils are peaked, the power meter should indicate above 4.0 watt.
5. Turn L306 counterclockwise until the power reading of 4.0 watt is obtained.

Parts Layout. Main PC Board.

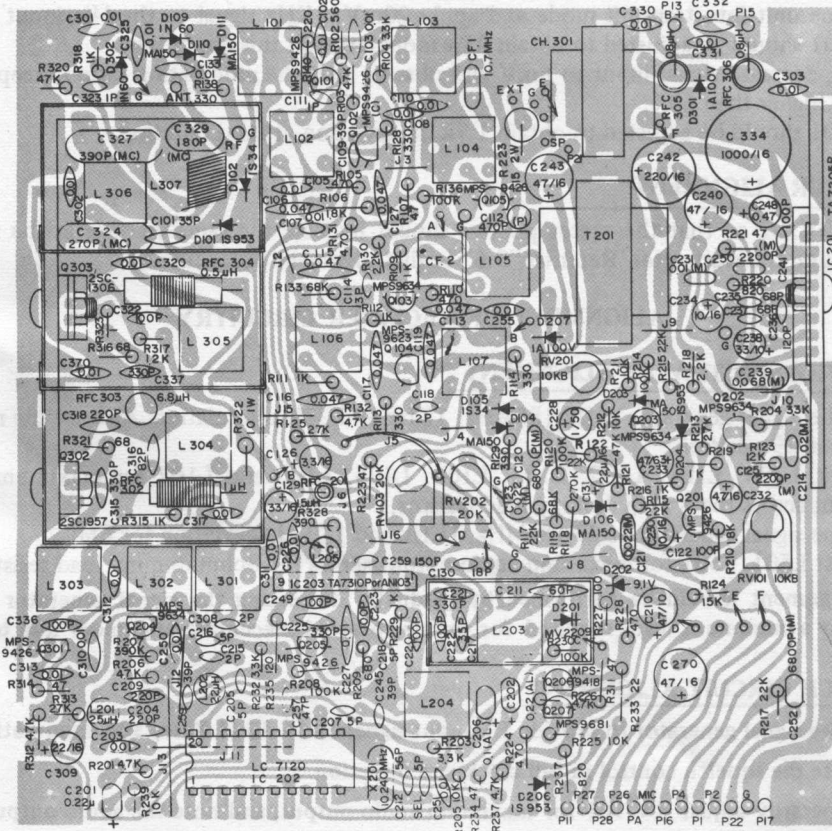

FIGURE 5. ADJUSTMENTS

TRANSMIT FREQUENCY CHECK

1. Set the Radio to transmit mode with no modulation.
2. Connect the frequency counter to the antenna load or to the tab provided at the wattmeter.

The frequency should be within $\pm 800\text{Hz}$ from each channel center frequency as tabulated in the frequency table attached.

MODULATION SENSITIVITY ALIGNMENT

1. Set toe unit into transmit mode and apply 20mV, 1KHz signal to the Mic input circuit.
2. RV201 should be adjusted to obtain 85% modulation at this condition.
3. Next, decrease signal input to 6mV and observe that the modulation ratio is keeping the value higher than 60%.
4. RV501 should be adjusted to obtain 1.7KHz deviation at this condition.

RF METER ALIGNMENT

Adjust RV202 so that the meter pointer should indicate the same wattage as the reading obtained on the wattmeter. Refer to "3.6" in this alignment procedure.

ALIGNMENT OF RECEIVER CIRCUITRY

RECEIVER SENSITIVITY ALIGNMENT

1. Set the signal generator at 27.185MHz, 1KHz and 30% modulation. Also set the radio at channel 19 position.
2. Adjust L204, L101, L102, L103, L104, L105, L106 and L107 for maximum audio output across the 8 ohm dummy load resistor.
3. Set the signal generator at 27.185MHz, 1KHz and 1.7KHz deviation for FM.
4. Adjust L501, T501 for maximum audio output across the 8ohm dummy load resistor.

This alignment should be performed by gradually decreasing the signal generator output signal to a minimum level required for tuning to avoid inaccurate alignment due to AGC action.

SQUELCH CIRCUIT ALIGNMENT

1. Set the signal generator to provide RF input signal of 54 dB (1 KHz, 30% modulation.)
2. Rotate the squelch control in full clockwise direction.
3. Temperarily adjust RV 101 for maximum audio output, and note the audio output level. Then, adjust RV 101 so that the audio output level decreases by 6dB.

S-METER ADJUSTMENT

1. Set the signal generator to provide 40 dB signal output.
2. Adjust RV103 so that the S-indicator read S "9" on the indicator provided on the front panel.

RETURNING THE UNIT FOR SERVICE

In the event repair is necessary please return unit to the store from which it was purchased. If necessary to return to our service head quarters, pack your transceiver extremely carefully. Use UPS prepaid. Please enclose a description of difficulty experienced as well as when and where unit was purchased.

